

LV-10.14.07-PP - 08818

Primary Usage

Reference No.

Sign. and date

Copy inv. No.

Repl. Inv. No.

Sign. and date

Orig. Inv. No.

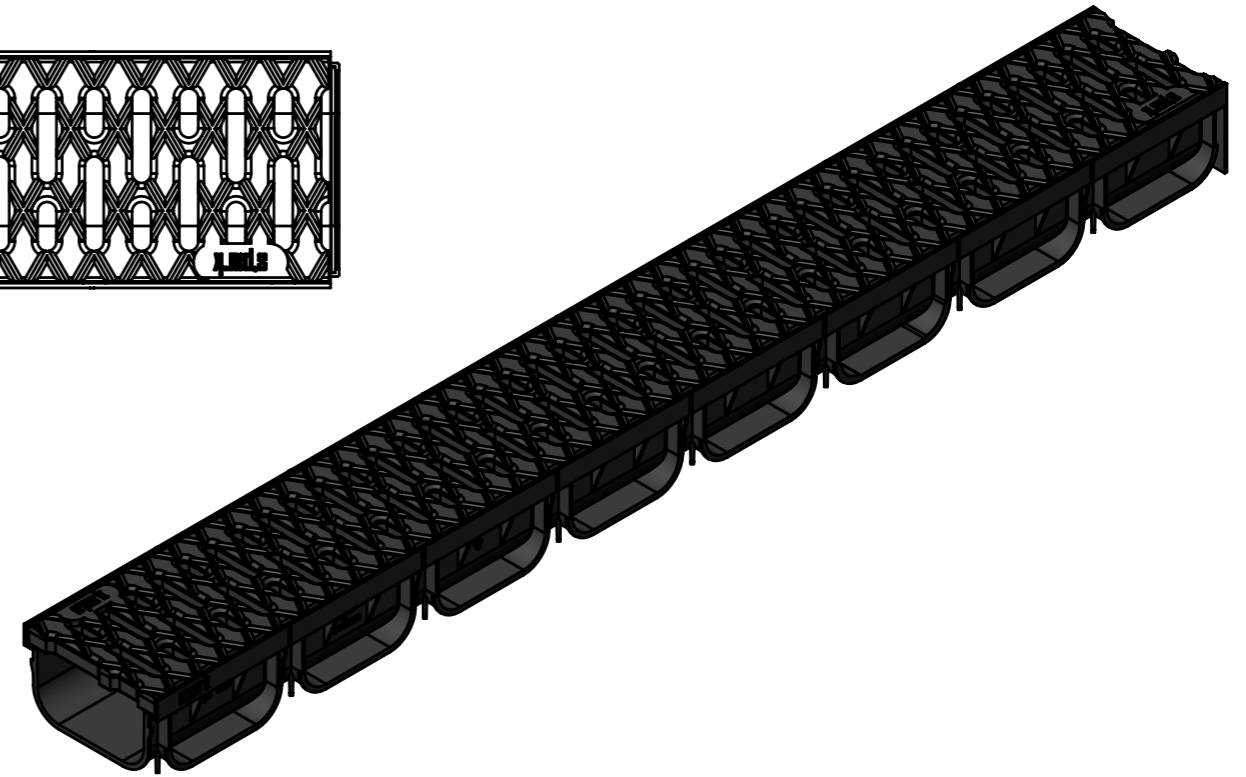
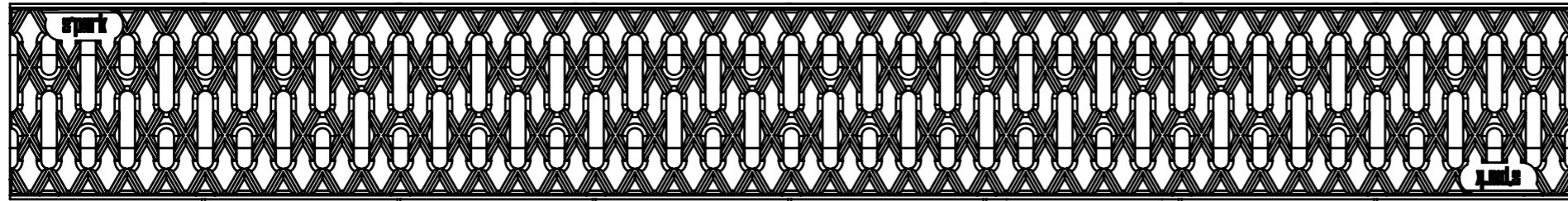
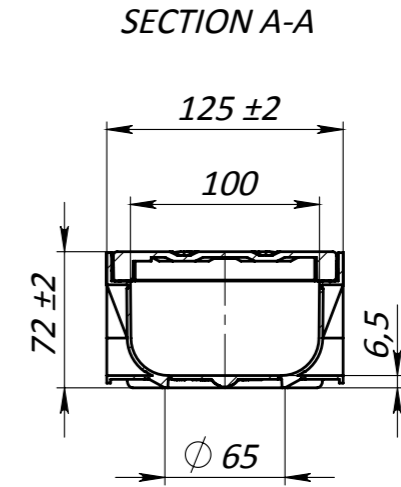
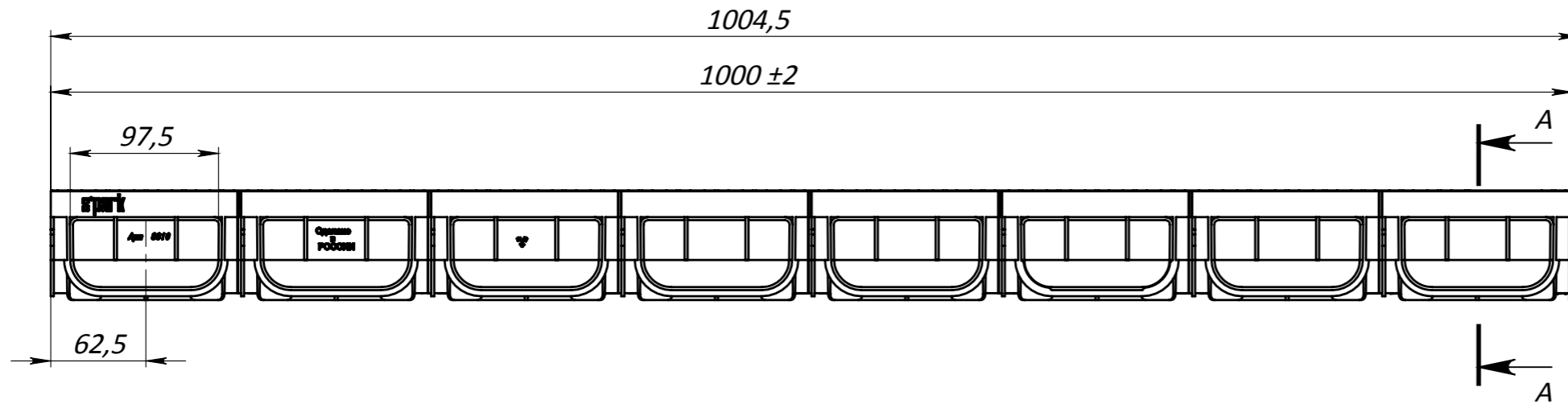

1. Powierzchnia przelotowa wody 270cm²

					Art.	08818
					LV-10.14.07-PP - 08818	
					Let.	Waga
						Skala
						1:4
					Strona	Strony 1
					Klasa obciążenia A	
					Plastik	